

RoHS Compliant



No.E-9413

Step Clamps

Material S45C **Heat Treatment** HRC30 ± 5 heat treatment

Surface Treatment Blackened

- Used paired with step blocks.

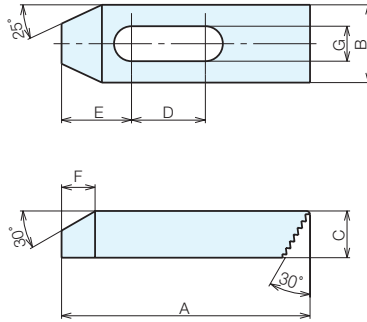

Specifications

Order No.	No.	Compatible Bolts	A	B	C	D	E	F	G	Weight (kg)
901106	STC0101	M8	60	25	12	21	20	11	9	0.06
901993	STC0102	M8	100	25	16	38	23	14	9	0.12
901994	STC0103	M8	150	25	19	73	27	17	9	0.24
901995	STC0201	M10	60	25	12	19	22	11	11	0.06
901996	STC0202	M10	100	25	16	38	25	14	11	0.12
901997	STC0203	M10	150	25	19	56	28	17	11	0.26
901998	STC0301	M12	60	25	12	18	23	11	13	0.06
901999	STC0302	M12	100	32	19	32	28	17	13	0.17
902000	STC0303	M12	150	32	22	51	33	19	13	0.29
902001	STC0401	M16	60	32	16	10	27	14	18	0.08
902002	STC0402	M16	100	38	19	31	31	17	18	0.20
902003	STC0403	M16	150	38	22	48	33	19	18	0.35
902004	STC0501	M20	100	38	19	27	31	17	22	0.19
902005	STC0502	M20	150	38	25	48	38	22	22	0.37
902006	STC0503	M20	200	50	30	80	41	25	22	0.68
902007	STC0601	M22	150	50	32	42	44	27	24	0.65
902008	STC0602	M22	200	50	32	70	47	30	24	0.95
902009	STC0603	M22	250	50	38	102	52	33	24	1.28
902010	STC0701	M24	150	50	32	42	46	27	26	0.65
902011	STC0702	M24	200	50	32	70	49	30	26	0.90
902012	STC0703	M24	250	50	38	102	52	33	26	1.22

Usage Examples

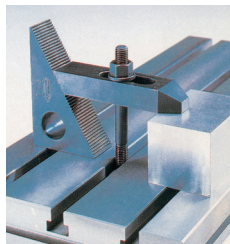
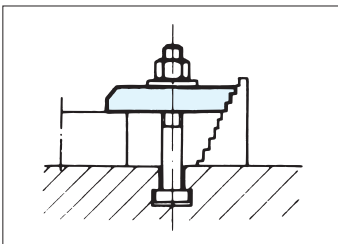

Reference Pages

Step Blocks



P.123 ▶