



RoHS Compliant

ERON®

No.E-9176

Screw Jack

Material S45C

Heat Treatment Main body:HRC30 ± 4 heat treatment
Screw:HRC35 ± 4 heat treatment

Surface Treatment Blackened

- For the SJK type, the attachment No.E-9175A can be used.
- For the SJK-K type, there is a through hole at the center of the jack so that the jack can be fixed using a bolt or the like.

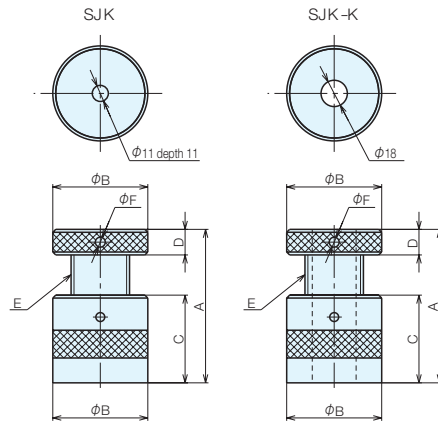

Specifications and Prices

Order No.	No.	A	B	C	D	E	F	Allowable Load (kN)	Weight (kg)
930261	SJK40	30-40	40	20	9.5	Tr25P4	4.1	20	0.28
930262	SJK50	40-50	50	26	13.5	Tr32P4	5.1	35	0.58
930263	SJK80	60-80	50	46	13.5	Tr32P4	5.1	35	0.88
930264	SJK105	80-105	65	60	17.5	Tr40P4	6.1	58	2.00
930265	SJK150	100-150	65	81	17.5	Tr40P4	6.1	58	2.54
930266	SJK250	150-250	65	132	17.5	Tr40P4	6.1	58	3.82
940491	SJK105K	80-105	65	60	17.5	Tr40P4	6.1	58	1.88
940492	SJK150K	100-150	65	81	17.5	Tr40P4	6.1	58	2.38
940493	SJK250K	150-250	65	132	17.5	Tr40P4	6.1	58	3.56

Lock Nut

Material S45C Heat Treatment HRC35 ± 4 heat treatment

Surface Treatment Blackened

Specifications and Prices

Order No.	No.	Compatible Models	Weight (kg)
940494	SJK-65LN	SJK-105·150·250(K)	0.23

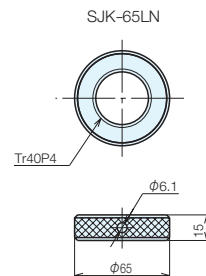

Usage Examples

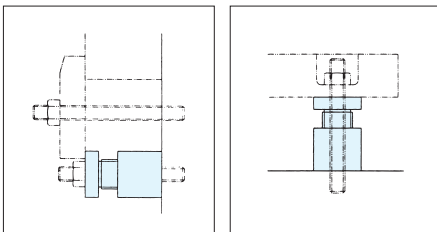

Reference Pages

Adjustable Hook Spanner



Attachment for Clamping Support Jack



P.125

Jig Set-up Systems
(Q-lock)

Base Elements

Clamp Units

Clamping Parts

Mechanical Parts

Machine Vises

Surface Plates and
Measurement Instruments

Index