

RoHS Compliant

No.E-9159

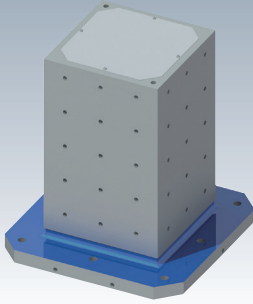

MC Tooling Blocks (4 Faces/Standard Tapped Holes Type)

Material FC250 **Heat Treatment** Annealing

Surface Treatment Painting (Cast Surface)

Accessories Top Plates, Set Screws for Top Plate, Eye Bolts

- Type with T-slots and U-slots in addition to the standard specifications.
- 0.4-0.5mm of self-cut allowance is included on the used surface.
- The same accuracy as the machine you are using is possible from the self-cut.
- Bottom and 2 adjacent edge locator surfaces can be ground finish, and top surface of base plate can be machined finish as options.

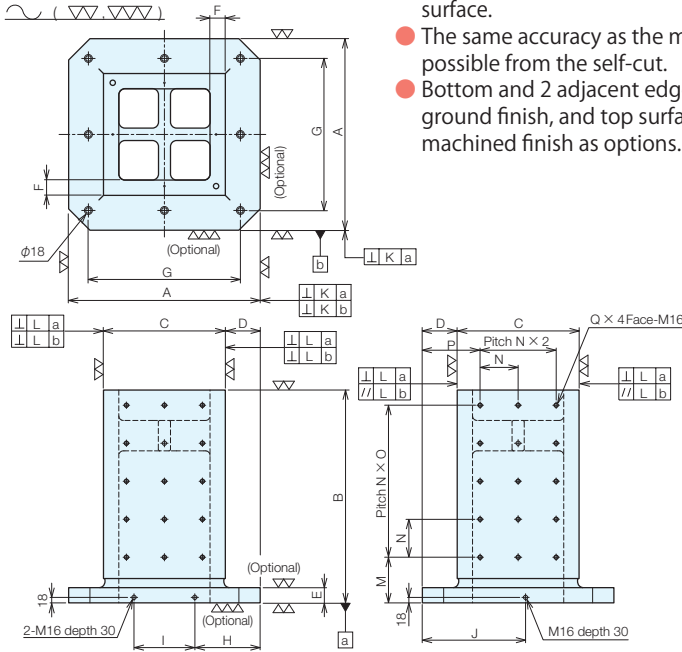

Size Chart

No.	A	E	F	G	Number of Mounting Holes	H	I	J	K	L
TPH04-****	400	50	50	320	4	145	110	225	0.02/300	0.02/300
TPH05-****	500	50	50	400	4	175	150	275	0.02/300	0.02/300
TPH06-****	630	50	50	500	8	215	200	340	0.02/300	0.02/300
TPH08-****	800	50	50	640	8	265	270	425	0.02/300	0.02/300

Optional Ground Finish and Machined Finish

No.	K	L
□ 400	0.01/500	0.01/300
□ 500	0.01/500	0.01/300
□ 630	0.01/500	0.01/300
□ 800	0.01/500	0.01/300

Please specify your desired dimensions and weight.

Palette Size	B	C	M
N	O	P	Used Surface Tapping Hole Diameter
Weight (kg)			

Specifications

Order No.	No.	B	C	D	M	N	O	P	Q	Weight (kg)
115334	TPH04-20045	450	200.8	99.6	100	75	4	125	15	138
115335	TPH04-25050	500	250.8	74.6	125	75	4	125	15	178
115336	TPH04-20055	550	200.8	99.6	100	75	5	125	18	160
115337	TPH04-25055	550	250.8	74.6	125	75	5	125	18	192
115338	TPH04-25060	600	250.8	74.6	150	75	5	125	18	207
115339	TPH05-25055	550	250.8	124.6	150	100	3	150	12	228
115340	TPH05-30055	550	300.8	99.6	150	100	3	150	12	259
115341	TPH05-35055	550	350.8	74.6	150	100	3	150	12	289
115342	TPH05-30065	650	300.8	99.6	150	100	4	150	15	296
115343	TPH05-25070	700	250.8	124.6	125	100	5	150	18	272
115344	TPH06-30060	600	301	164.5	150	125	3	190	12	338
115345	TPH06-45060	600	451	89.5	150	125	3	190	12	437
115346	TPH06-40070	700	401	114.5	150	125	4	190	15	457
115347	TPH06-30075	750	301	164.5	150	125	3	190	12	393
115348	TPH06-45075	750	451	89.5	150	125	4	190	15	525
115349	TPH08-40070	700	401	199.5	150	150	3	250	12	643
115350	TPH08-50080	800	501	149.5	150	150	4	250	15	844
115351	TPH08-55090	900	551	124.5	150	150	4	250	15	1009

* Custom-made products to suit your specifications are also available.

Jig Set-up Systems (Q-lock)

Base Elements

Clamp Units

Clamping Parts

Mechanical Parts

Machine Vises

Surface Plates and Measurement Instruments

Index