

RoHS Compliant

No.E-9159L

MC Tooling Blocks (4 Faces/Light Weight Type)

Material FCD600 **Heat Treatment** Annealing

Surface Treatment Painting (Cast Surface)

Accessories Top Plates, Set Screws for Top Plate, Eye Bolts

- Angle plate that delivers light weight while ensuring rigidity by using slanted surfaces and a rib structure.
- Shape that makes it hard for chips to remain.
- 0.4-0.5mm of self-cut allowance is included on the used surface.
- The same accuracy as the machine you are using is possible from the self-cut.
- Your preferred machining such as tapping and grooves can be done using the machine you are using.
- Bottom and 2 adjacent edge locator surfaces can be ground finish as options.

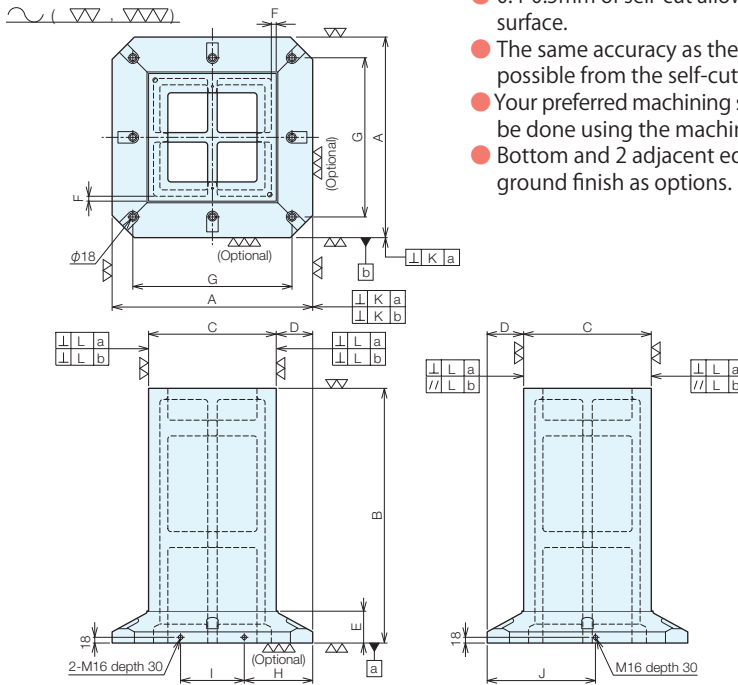

Size Chart

No.	A	F	G	Number of Mounting Holes	H	I	J	K	L
TBL03-****	300	20	-	0	-	-	-	0.02/300	0.02/300
TBL04-****	400	25	320	4	145	110	225	0.02/300	0.02/300
TBL05-****	500	25	400	4	175	150	275	0.02/300	0.02/300
TBL06-****	630	35	500	8	215	200	340	0.02/300	0.02/300
TBL08-****	800	35	640	8	265	270	425	0.02/300	0.02/300

Optional - Ground Finish

No.	K	L
<input type="checkbox"/> 300	0.01/500	0.01/300
<input type="checkbox"/> 400	0.01/500	0.01/300
<input type="checkbox"/> 500 (Up to height 800)	0.01/500	0.01/300
<input type="checkbox"/> 500 (Height 850 and over)	0.01/500	0.01/300
<input type="checkbox"/> 630 (up to height 800)	0.01/500	0.01/300
<input type="checkbox"/> 630 (height 850 or more)	0.01/500	0.01/300
<input type="checkbox"/> 800	0.01/500	0.01/300

Specifications

Order No.	No.	B	C	D	E	Weight (kg)
115352	TBL03-15035	350	150.8	74.6	65	43
115353	TBL04-25055	550	250.8	74.6	85	139
115354	TBL04-25060	600	250.8	74.6	85	148
115355	TBL04-22065	650	225.8	87.1	85	146
115356	TBL04-25065	650	250.8	74.6	85	157
115357	TBL04-20070	700	200.8	99.6	85	142
115358	TBL04-22070	700	225.8	87.1	85	154

Order No.	No.	B	C	D	E	Weight (kg)
115359	TBL04-25070	700	250.8	74.6	85	166
115360	TBL05-35055	550	350.8	74.6	80	198
115361	TBL05-35060	600	350.8	74.6	80	210
115362	TBL05-30065	650	300.8	99.6	100	219
115363	TBL05-35065	650	350.8	74.6	80	223
115364	TBL05-30070	700	300.8	99.6	100	221
115365	TBL05-35070	700	350.8	74.6	80	235
115366	TBL05-25075	750	250.8	124.6	100	204
115367	TBL05-30075	750	300.8	99.6	100	232
115368	TBL05-35075	750	350.8	74.6	80	248
115369	TBL05-25080	800	250.8	124.6	100	213
115370	TBL05-30080	800	300.8	99.6	100	243
115371	TBL05-35080	800	350.8	74.6	80	260
115372	TBL05-25085	850	250.8	124.6	100	222
115373	TBL05-30085	850	300.8	99.6	100	253
115374	TBL05-35085	850	350.8	74.6	80	273
115375	TBL05-25090	900	250.8	124.6	100	231
115376	TBL05-30090	900	300.8	99.6	100	264
115377	TBL05-35090	900	350.8	74.6	80	285
115378	TBL06-45070	700	451	89.5	90	411
115379	TBL06-45075	750	451	89.5	90	434
115380	TBL06-40080	800	401	114.5	100	427
115381	TBL06-45080	800	451	89.5	90	456
115382	TBL06-40085	850	401	114.5	100	447
115383	TBL06-45085	850	451	89.5	90	478
115384	TBL06-35090	900	351	139.5	110	429
115385	TBL06-40090	900	401	114.5	100	467
115386	TBL06-45090	900	451	89.5	90	501
115387	TBL06-35095	950	351	139.5	110	446
115388	TBL06-40095	950	401	114.5	100	487
115389	TBL06-45095	950	451	89.5	90	523
115390	TBL06-35100	1000	351	139.5	110	462
115391	TBL06-40100	1000	401	114.5	100	505
115392	TBL06-45100	1000	451	89.5	90	545
115393	TBL08-55080	800	551	124.5	110	636
115394	TBL08-50085	850	501	149.5	120	633
115395	TBL08-55085	850	551	124.5	110	663
115396	TBL08-50090	900	501	149.5	120	658
115397	TBL08-55090	900	551	124.5	110	691
115398	TBL08-45095	950	451	174.5	130	646
115399	TBL08-50095	950	501	149.5	120	683
115400	TBL08-55095	950	551	124.5	110	718
115401	TBL08-45100	1000	451	174.5	130	668
115402	TBL08-50100	1000	501	149.5	120	707
115403	TBL08-55100	1000	551	124.5	110	746
115404	TBL08-45105	1050	451	174.5	130	690
115405	TBL08-50105	1050	501	149.5	120	732
115406	TBL08-55105	1050	551	124.5	110	773
115407	TBL08-40110	1100	401	199.5	140	667
115408	TBL08-45110	1100	451	174.5	130	713
115409	TBL08-50110	1100	501	149.5	120	757
115410	TBL08-55110	1100	551	124.5	110	800
115411	TBL08-40120	1200	401	199.5	140	706
115412	TBL08-45120	1200	451	174.5	130	757
115413	TBL08-50120	1200	501	149.5	120	807
115414	TBL08-55120	1200	551	124.5	120	855

* Custom-made products to suit your specifications are also available.

Please specify your desired dimensions and weight.

Palette Size	B	C	Weight (kg)

Jig Set-up Systems
(Q-lock)

Base Elements

Clamp Units

Clamping Parts

Mechanical Parts

Machine Vises

Surface Plates and
Measurement Instruments

Index