

RoHS Compliant

NBK®

No.E-9123

# Leveling Block Type AN

- Not having a flange, which type A has, this type can be placed in a narrow space.
- Easy to install on a stand for surface plate.
- Offers the same features, mechanism and capacity as type A.

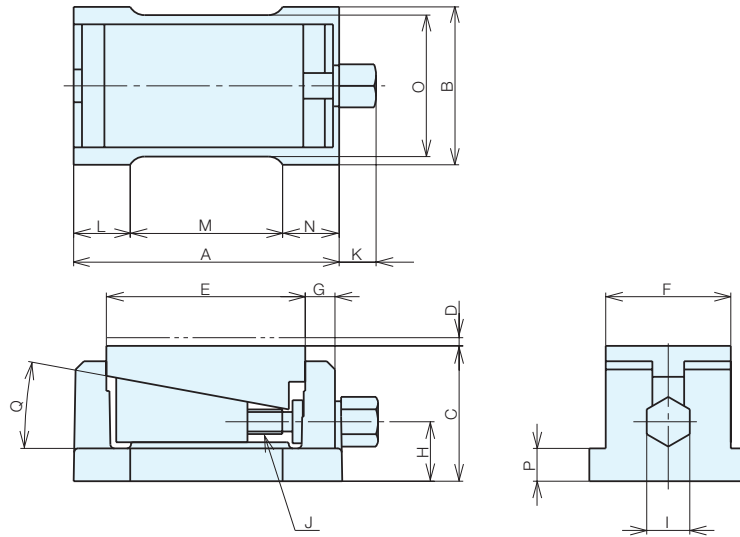

## Size Chart

No.	A	B	C	D	E	F	G	H
AN1	129	73	66	4	95	62	17	29
AN2	172	105	80	5	130	84	21	34
AN3	215	126	101	6	159	100	29	43
AN4	215	126	101	6	159	100	29	43

No.	I	J	K	L	M	N	O	P	Q
AN1	21	M12 × 1.75 (coarse thread)	17	32	65	32	69	15	10° 26'
AN2	26	M16 × 2 (coarse thread)	19.5	36.5	99	36.5	100	17	10° 26'
AN3	29	M20 × 2.5 (coarse thread)	24	47	121	47	120	22	10° 26'
AN4	35	φ 19 trapezoidal thread 6 threads per inch	25	47	121	47	120	22	10° 26'

## Specifications

Order No.	No.	Stroke	Lifting Height	Maximum Allowable Load (kN)	Weight (kg)
950736	AN1	66- 70	4	7	3.1
950737	AN2	80- 85	5	15	7.7
950738	AN3	101-107	6	25	14.4
950739	AN4	101-107	6	45	14.4

Jig Set-up Systems (Q-lock)  
Base Elements  
Clamp Units  
Clamping Parts  
Mechanical Parts  
Machine Vises  
Surface Plates and Measurement Instruments  
Index