

RoHS Compliant

NBK®

No.E-9123

Leveling Block Type A

- Offers high accuracy.
- Reduces installation work cost.
- Offers the best rigidity.
- Facilitates installation.
- Most suitable for installing machines such as milling machines, radial drilling machines, planers and surface plates.

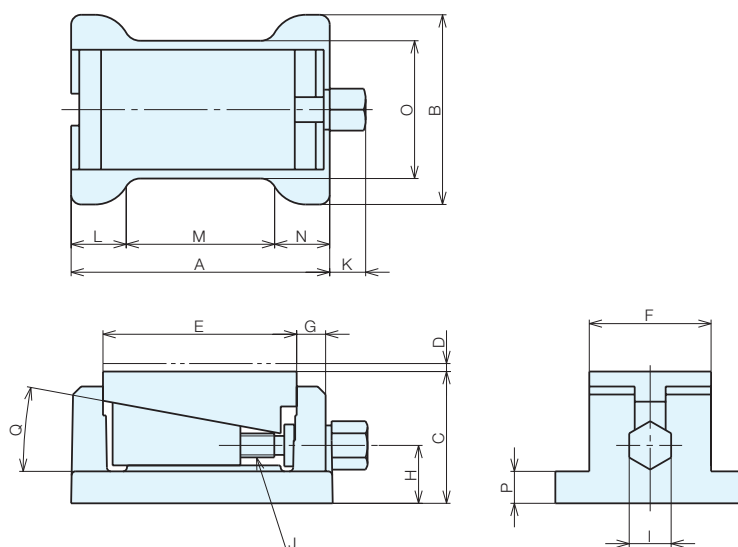

Size Chart

No.	A	B	C	D	E	F	G	H
A1	129	95	66	4	95	62	15	29
A2	172	142	80	5	130	84	18	35
A3	215	165	101	6	159	100	26	43
A4	215	165	101	6	159	100	26	43

No.	I	J	K	L	M	N	O	P	Q
A1	21	M12 × 1.75 (coarse thread)	17	30	69	30	69	15	10° 26'
A2	26	M16 × 2 (coarse thread)	19.5	35	102	35	100	17	10° 26'
A3	29	M20 × 2.5 (coarse thread)	24	45	125	45	120	22	10° 26'
A4	35	φ 19 trapezoidal thread 6 threads per inch	25	45	125	45	120	22	10° 26'

Specifications and Prices

Order No.	No.	Stroke	Lifting Height	Maximum Allowable Load (kN)	Weight (kg)
902091	A1	66- 70	4	7	3.3
902092	A2	80- 85	5	15	8
902093	A3	101-107	6	25	15
902094	A4	101-107	6	45	15

Jig Set-up Systems
(Q-lock)

Base Elements

Clamp Units

Clamping Parts

Mechanical Parts

Machine Vises

Surface Plates and
Measurement Instruments

Index