



Box Vee Blocks

Material FC250(Main body, join fitting)
Steel (other)

Heat Treatment Annealing (FC250)

Used Surface Machined finish, hand scraped finish

- Useful for temporary fixing when measuring round materials.
- Can also be used as square type blocks.

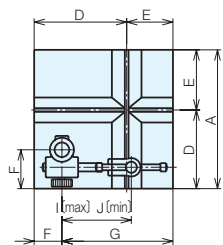

Perpendicularity of 4 faces to face [a]		
Perpendicularity of 4 faces to face [b]		
Perpendicularity of 4 faces to face [c]	Class A (machined finish)	0.05
Parallelism of opposite face to face [a]	Class AA (ground finish)	0.03
Parallelism of opposite face to face [b]	Class AAA (hand scraped finish)	0.02
Parallelism of opposite face to face [c]		
Precision of X		

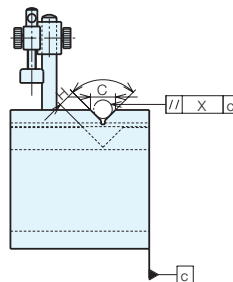
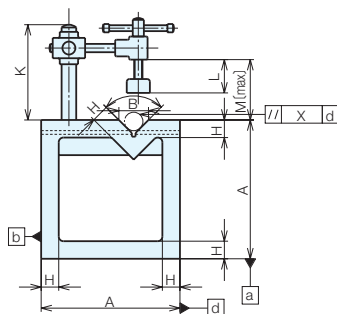

Size Chart

No.	A	B	C	D	E	F	G	H	I	J	K	L	M	Weight (kg)
100	100	20	18	60	40	24	76	13	80	45	100	25	57	4.1
125	125	26	20	80	45	30	95	15	90	45	110	25	67	7.8
150	150	32	27	100	50	36	114	19	119	50	130	43	84	13.5
200	200	38	32	136	64	55	145	25	194	50	170	43	128	27.0
250	250	46	37	174	76	65	185	32	219	52	250	64	199	49.5
300	300	60	50	205	95	80	220	38	244	52	300	64	249	79.0

Specifications

Machined Finish			Ground Finish			Hand scraped finish		
Order No.	No.		Order No.	No.		Order No.	No.	
901166	AK100		901171	AA100		901178	AAA100	
901167	AK125		901172	AA125		901179	AAA125	
901168	AK150		901173	AA150		901180	AAA150	
901169	AK200		901174	AA200		901181	AAA200	
-	-	-	901175	AA250		901182	AAA250	
-	-	-	901176	AA300		901183	AAA300	