



RoHS Compliant



No.E-9918

Low Wedge Clamps

Part name	Material	Heat Treatment	Surface Treatment
Main body (metal part)	C3604BD	-	-
Main body (rubber part)	NBR	-	-
Clamping bolt	SCM435	HRC25 heat treatment	Blackened
Washers*	SCM435	HRC43 heat treatment	-

* Double-sided type only

Accessories Knock pin $\phi 3h7x6 \dots 1$ piece

Single-sided type/Double-sided type

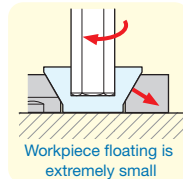
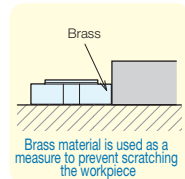
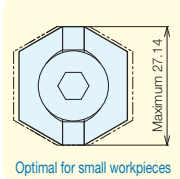

Single-sided type only

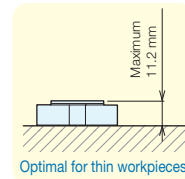

Double-sided type only

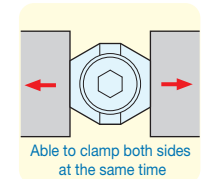

Specifications



Single-sided type

Order No.	No.	Screw Thread (Coarse Thread)	Maximum Clamp Height	Clamp Stroke	Maximum Torque N · m	Maximum Clamping Force kN	Weight kg
976031	LWC04	M4 × 0.7	3.9	0.4	1.6	0.9	1.4
976032	LWC06	M6 × 1.0	5.5	0.7	5.0	1.9	8.4
976033	LWC08	M8 × 1.25	6.0	1.0	13.0	4.3	16.0
976034	LWC12	M12 × 1.75	11.2	1.2	40.0	7.1	48.0



Double-sided type

Order No.	No.	Screw Thread (Coarse Thread)	Maximum Clamp Height	Clamp Stroke	Maximum Torque N · m	Maximum Clamping Force kN	Weight kg
976035	LWCD04	M4 × 0.7	6.7	0.4	1.6	0.9	1.3
976036	LWCD06	M6 × 1.0	10.6	0.7	5.0	1.9	8.4
976037	LWCD08	M8 × 1.25	13.1	1.0	13.0	4.3	16.0
976038	LWCD12	M12 × 1.75	22.0	1.2	40.0	7.1	46.0

* The clamp stroke and maximum clamping force are the values for one side.

External Dimensions

Single-sided type

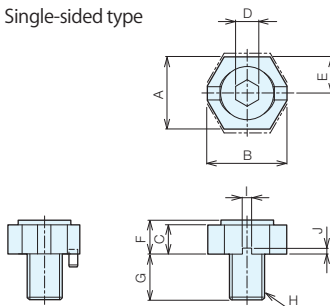

Double-sided type

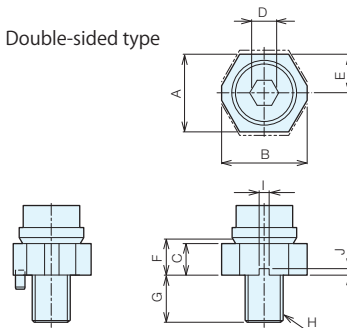

Single-sided type

No.	A	B	C	D	E	F (Max)	G	H (Coarse Thread)	I	J
LWC04	9.2	10.2	3	2.5	4.6 - 5.0	3.9	6	M4 × 0.7	-	-
LWC06	15.6	17.3	5	4	7.8 - 8.5	5.5	10	M6 × 1.0	3.2	2
LWC08	20	21.94	5	5	10.0 - 11.0	6	13	M8 × 1.25	3.2	2
LWC12	24.6	27.14	10	8	12.3 - 13.5	11.2	18	M12 × 1.75	3.2	2

Double-sided type

No.	A	B	C	D	E	F (Max)	G	H (Coarse Thread)	I	J
LWCD04	9.2 - 10	10.2	3	2	4.6 - 5.0	6.7	7	M4 × 0.7	-	-
LWCD06	15.6 - 17	17.3	5	3	7.8 - 8.5	10.6	11	M6 × 1.0	3.2	2
LWCD08	20 - 22	21.94	5	4	10.0 - 11.0	13.1	14	M8 × 1.25	3.2	2
LWCD12	24.6 - 27	27.14	10	6	12.3 - 13.5	22	17	M12 × 1.75	3.2	2

■ Usage Methods

⚠ Cautions

In this product, NBR (synthetic rubber) and adhesive are used in the main body
 Do not use solvents such as paint thinner, chlorine-based cutting fluids, or strongly alkaline cutting fluids as these can cause the rubber in the main body to damage.
 Do not open wider than the specified opening. Doing so may cause the rubber to break.

The rubber part of the main body is extended by tightening the clamping bolt using an allen key and clamps the workpiece on the metal part.
 When unclamped, it returns to its original dimensions due to the compression of the rubber.

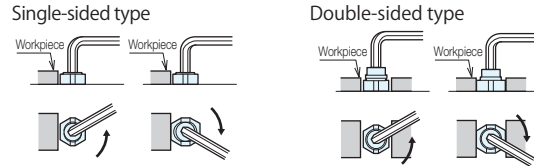

Set the position where the workpiece is clamped by referring to the mounting dimensions taking into account variations in workpiece dimensions.

The locating for clamping direction can be set using the included locating pin.

You can also clamp the workpiece vertically.

(LWC-04 cannot)

Single-sided type

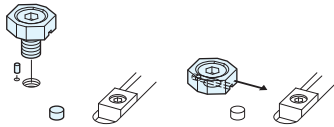

Double-sided type

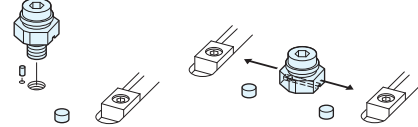

■ Component Parts

Single-sided type

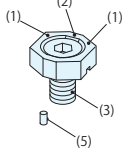

Double-sided type

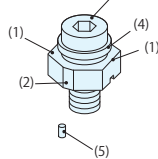

Component Parts	Component Parts
(1) Main body (metal part)	(4) Washers
(2) Main body (rubber part)	(5) Knock pin $\phi 3$
(3) Clamping bolt	

■ Mounting Dimensions

Single-sided type

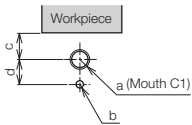

Double-sided type

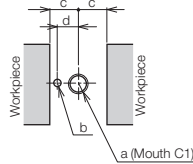

Single-sided type

No.	a (Coarse Thread)	b	c	d
LWC04	M4 × 0.7	-	4.7 - 4.9	-
LWC06	M6 × 1.0	$\phi 3H7$ depth 4.5 ± 0.2	7.9 - 8.2	6
LWC08	M8 × 1.25	$\phi 3H7$ depth 4.5 ± 0.2	10.1 - 10.7	8
LWC12	M12 × 1.75	$\phi 3H7$ depth 4.5 ± 0.2	12.4 - 13.2	10

Double-sided type

No.	a (Coarse Thread)	b	c	d	Maximum Difference Between Left and Right
LWCD04	M4 × 0.7	-	4.7 - 4.9	-	0.2
LWCD06	M6 × 1.0	$\phi 3H7$ depth 4.5 ± 0.2	7.9 - 8.2	6	0.3
LWCD08	M8 × 1.25	$\phi 3H7$ depth 4.5 ± 0.2	10.1 - 10.7	8	0.6
LWCD12	M12 × 1.75	$\phi 3H7$ depth 4.5 ± 0.2	12.4 - 13.2	10	0.8

Usage Examples

Single-sided type

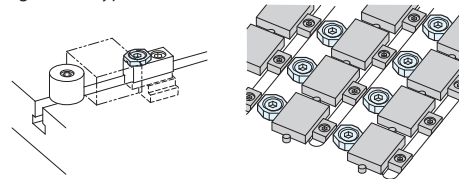

Double-sided type

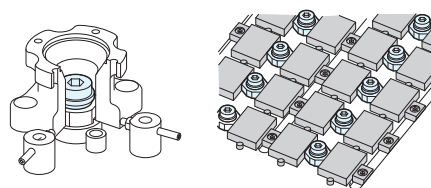

Jig Set-up Systems (Q-lock)

Base Elements

Clamp Units

Clamping Parts

Mechanical Parts

Machine Vises

Surface Plates and Measurement Instruments

Index